

RENAULT AUSTRAL E-TECH FULL HYBRID

200 HP



also available with mild hybrid advanced
and mild hybrid engines



a new hybrid vision of the SUV

Renault Austral E-Tech full hybrid is a game changer: up to 80% electric driving in town⁽¹⁾, esprit Alpine version, 4Control advanced system⁽²⁾ with 4-wheel steering, 774 cm² openR screens⁽²⁾, 210 cm² head-up display⁽²⁾ and Google built-in services⁽²⁾.



**An innovative and immersive
experience awaits you on board
Renault Austral E-Tech full hybrid.**

**200 hp E-Tech
full hybrid
engine⁽²⁾**

**32 advanced
driver-
assistance
systems⁽²⁾**

**984 cm²
of openR screens
and head-up
display⁽²⁾**

**4Control
advanced
technology⁽²⁾**

**673 L⁽³⁾
of boot
volume**

**version
esprit Alpine**

(1) depending on battery charge status and driving style/source Renault Internal/2022.
(2) depending on version or engine.
(3) 575 dm³ boot (VDA standard).

interactive menu

01. design

02. driving pleasure

03. driving experience

04. multimedia

05. interior space

06. advanced driver-assistance systems

07. customisation

PDF to be downloaded



equipment and engines



accessories

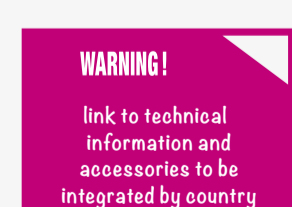

athletic design

Wide shoulders and a muscular bonnet for an intensely proportioned design. The glossy black⁽¹⁾ roof highlights the elegance of the lines. Contrasting side protection elements⁽¹⁾ reinforce the dynamic silhouette.



The result of the historic collaboration between the Renault and Alpine design teams, the esprit Alpine version asserts its dynamic character: 20" daytona black diamond-cut wheels, exclusive satin shale grey tint, shale grey sport blade at the front, black roof, satin black roof bars, distinctive badges.



20" daytona black diamond-cut alloy wheels with smoky grey clearcoat



esprit Alpine badge

There is also an Alpine touch in the passenger compartment: the Alcantara[®]/fabric upholstery is enhanced with blue top-stitching, the headrests feature exclusive embroidered motifs, and the aluminium pedal unit energises the cockpit. The textured Alcantara[®] coated steering wheel is covered with blue, white and red stitching.

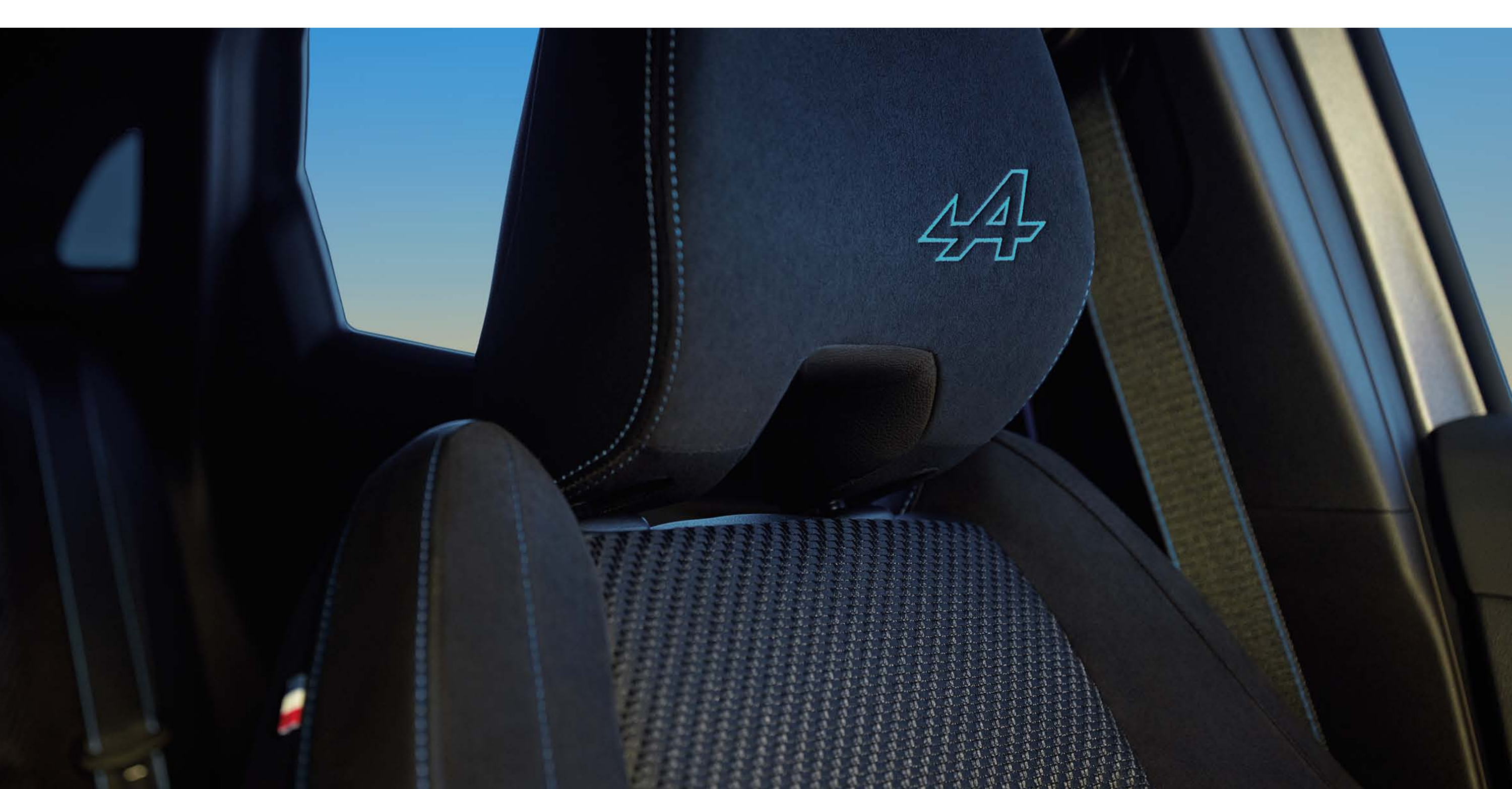

⁽¹⁾ depending on the version.

[configure and order →](#)

WARNING!
Link to the configurator to be integrated by the country

02. driving pleasure

the best of the hybrid

E-Tech
full hybrid
200 hp

up to
80%
electric driving in town⁽¹⁾

up to
130 km/h
in electric mode⁽¹⁾

up to
1,100 km
of driving range⁽²⁾

4.6 l/100 km
fuel consumption⁽³⁾

102 g/km
CO₂ emissions⁽³⁾



Discover the 100% hybrid range and its three engines: E-Tech full hybrid, an engine that boasts one of the most efficient levels of performance in its category⁽³⁾, mild hybrid advanced and mild hybrid.

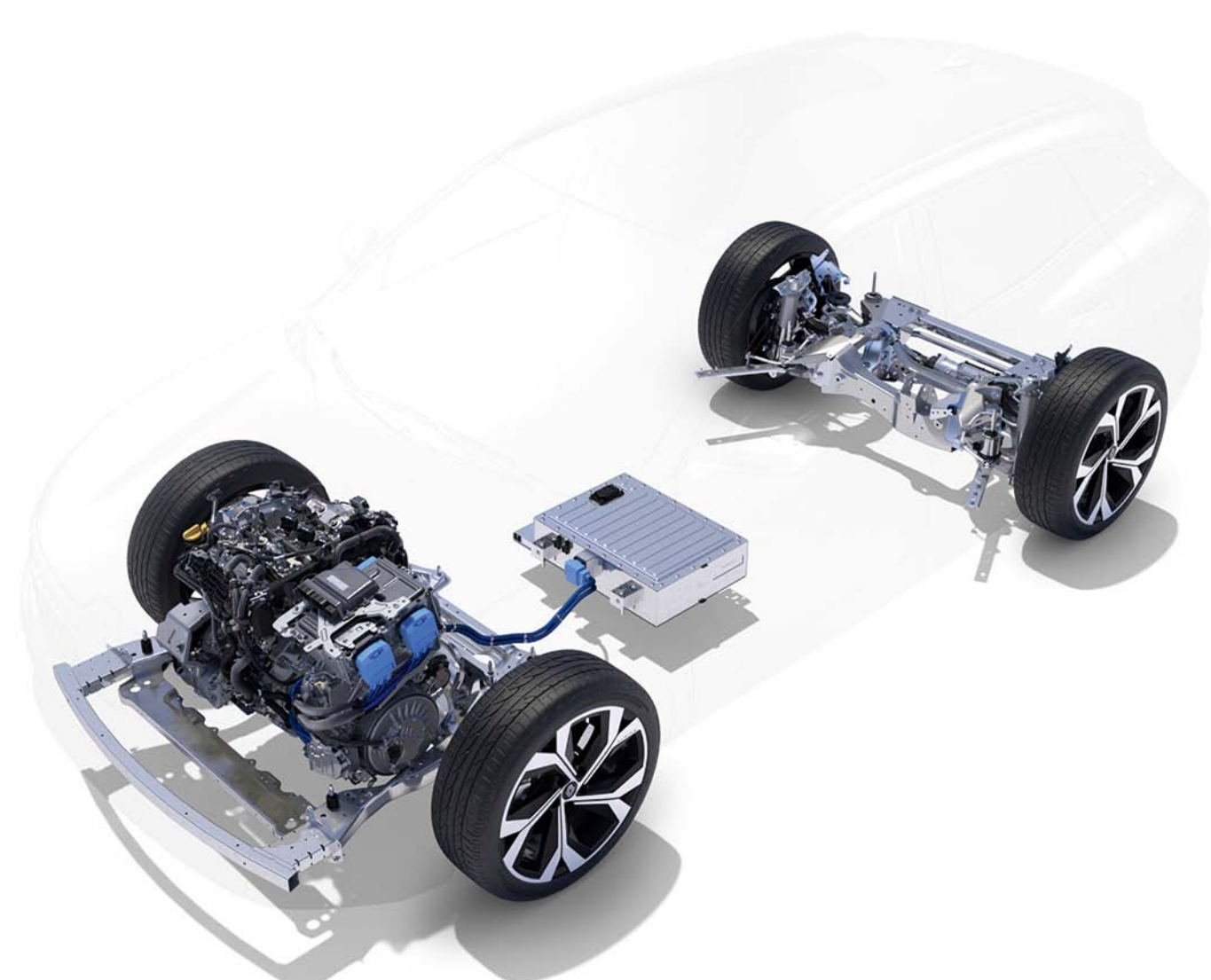

up to 40% fuel savings⁽⁴⁾ with the E-Tech full hybrid engine

In town, drive in electric mode⁽¹⁾ for up to 80% of your journey. The battery recharges during deceleration and braking: no need to plug in to recharge.

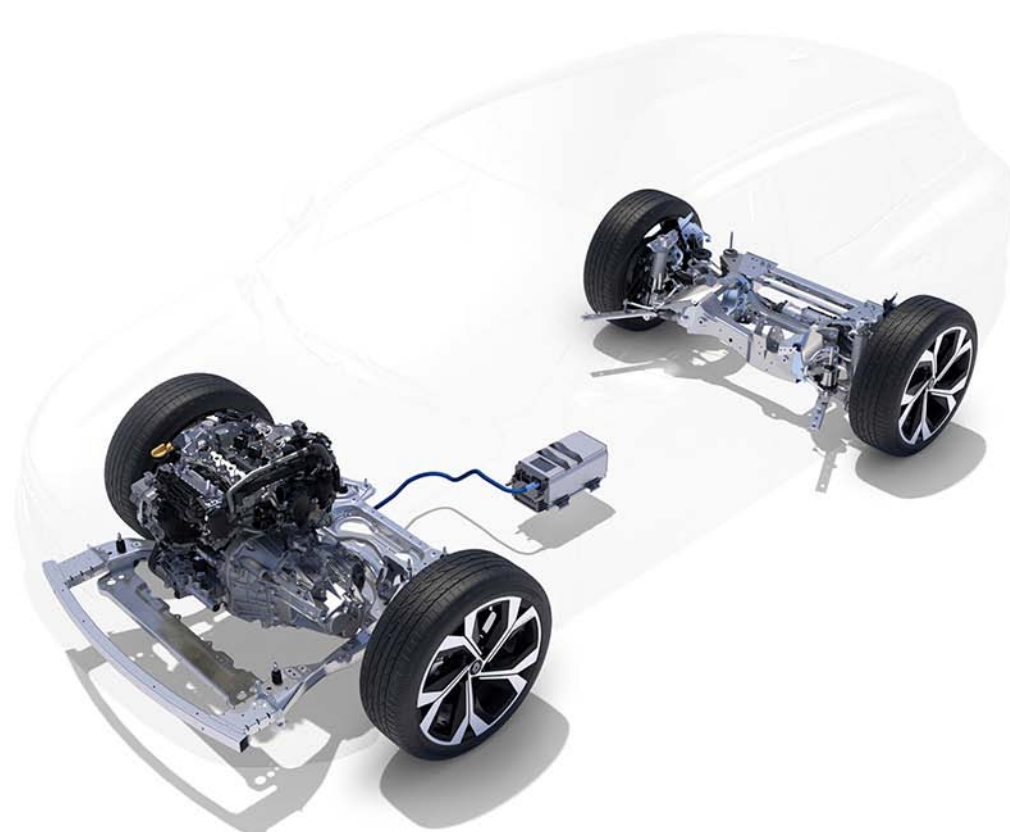

I.

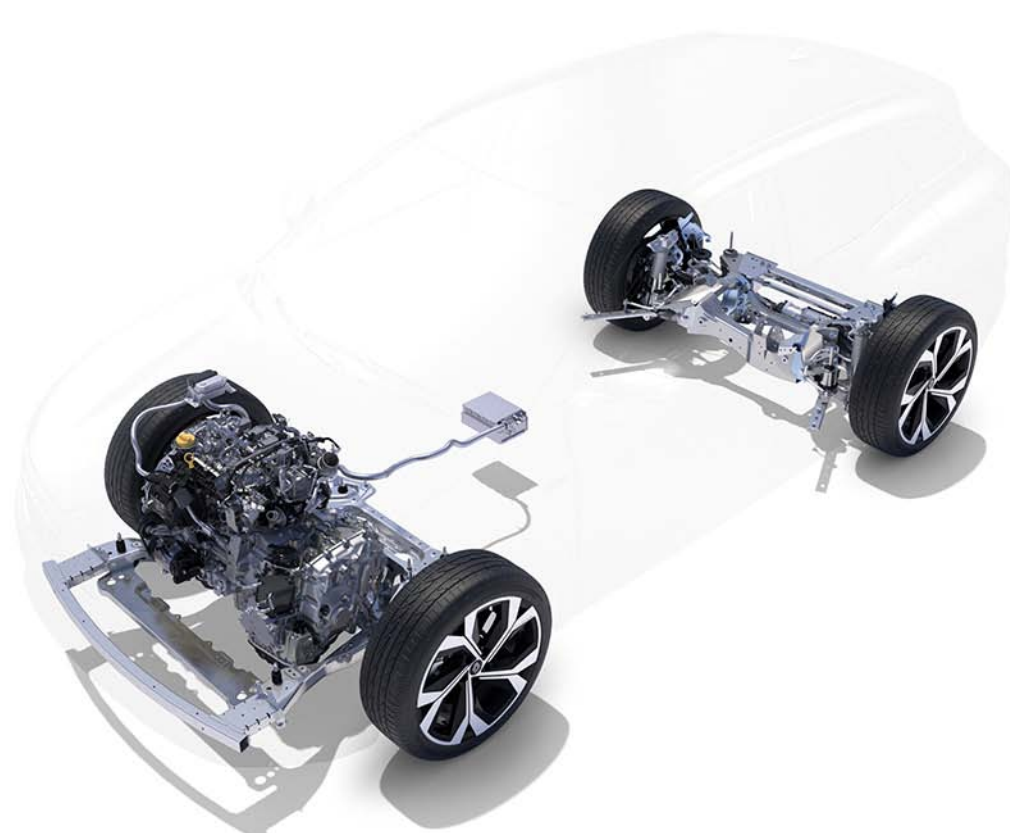

II.

mild hybrid advanced (I.) and mild hybrid (II.)

Electric hybridisation supports the engine in the acceleration phase to enhance the experience and reduce fuel consumption.

	E-Tech full hybrid 200	mild hybrid advanced 130	mild hybrid 160 auto
technology	1400V battery + 2 electric engines + 1 internal combustion engine	148V battery + 1 internal combustion engine	112V battery + 1 internal combustion engine
reduced fuel consumption⁽³⁾⁽⁴⁾	up to 40%	up to 20%	up to 8%
fuel consumption⁽⁴⁾	from 4.6 l/100 km	from 5.2 l/100 km	from 6.1 l/100 km
CO₂ emissions⁽⁴⁾	from 102 g/km	from 118 g/km	from 139 g/km
Crit'Air rating	X	X	X
energy recovery via deceleration and braking	yes	yes	yes
management of the level of energy recovery	yes	no	no
electric assistance to the internal combustion engine	yes	yes	yes
electric driving in town⁽⁴⁾	up to 80% electric driving in town ⁽¹⁾	no	no

(1) depending on battery charge status and driving style / Renault internal source / 2022.

(2) up to 1,100 km of driving range with a full tank of petrol according to WLTP data.

(3) values type-approved according to version/in accordance with WLTP protocol / UTAC source/July 2022.

(4) for an E-Tech full hybrid engine compared with a mild hybrid auto engine, according to WLTP City protocol / UTAC & IDIADA source / September 2022.

configure and order →



4Control advanced⁽¹⁾

The 4Control advanced⁽¹⁾ system with 4-wheel steering makes driving safer and more precise.



The 10.1 m turning circle is comparable to that of a city car.

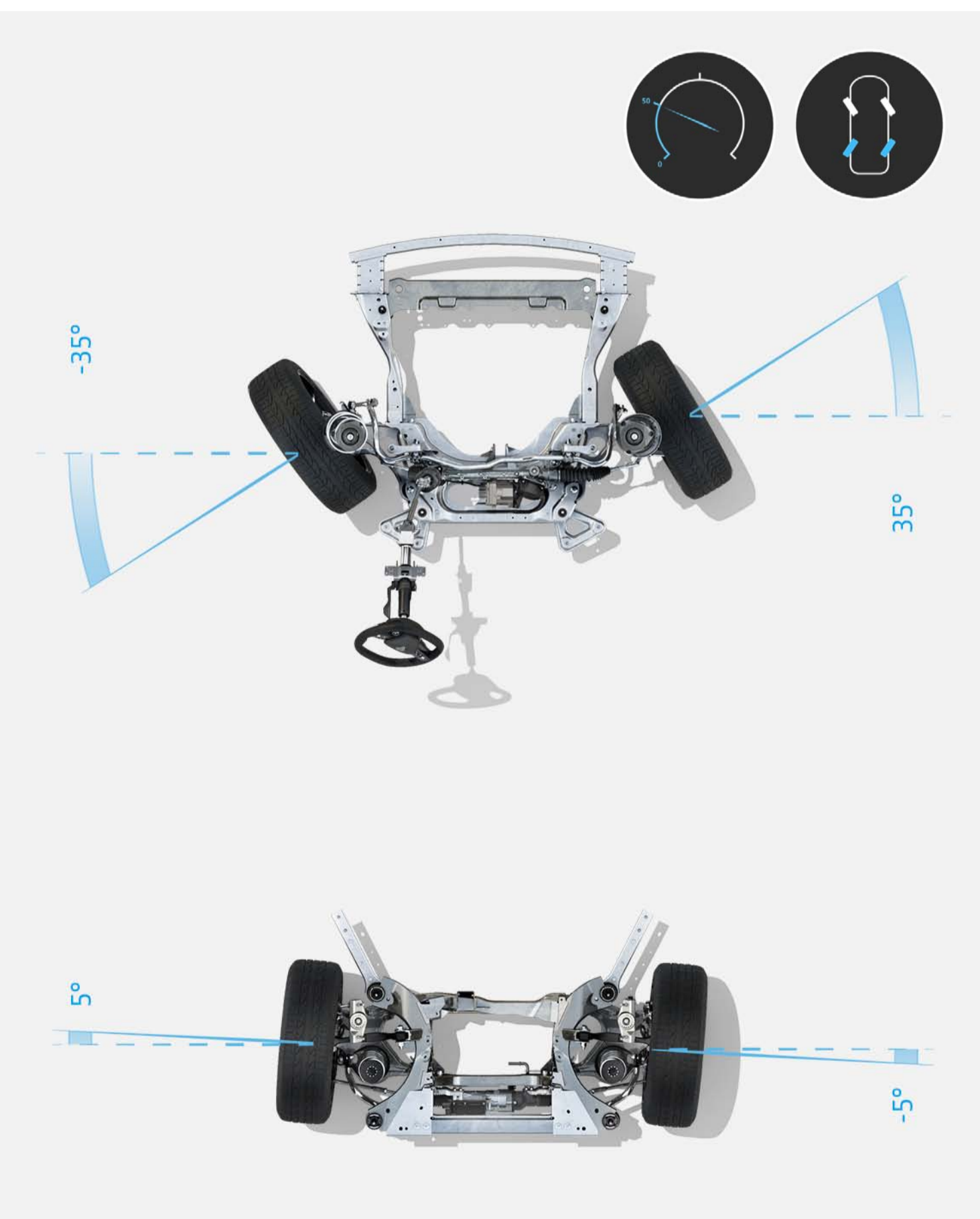

up to 50 km/h, the rear wheels turn in the opposite direction to the front wheels to reduce the turning circle

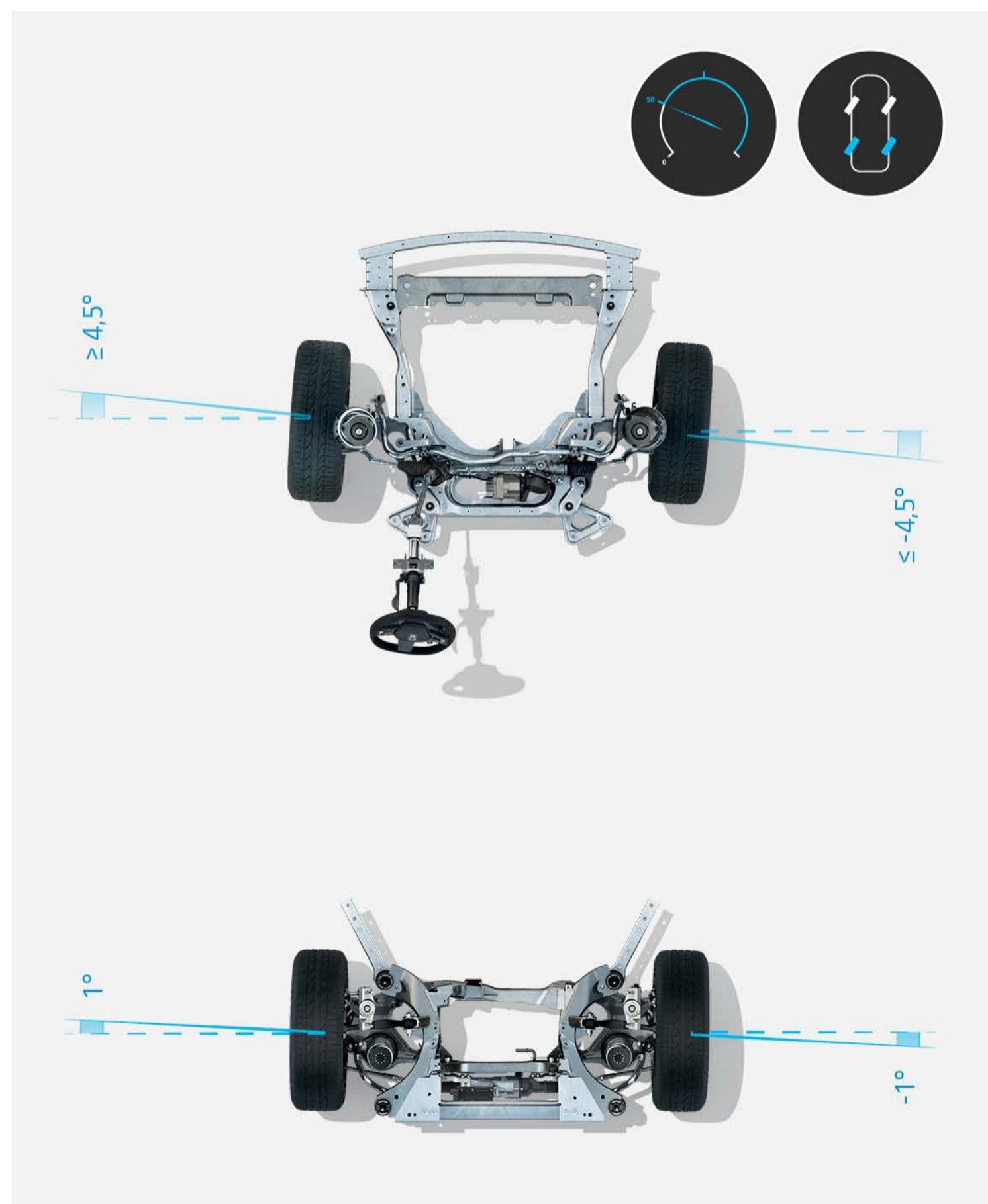

above 50 km/h, the rear wheels turn in the same direction as the front wheels to improve road holding and safety

⁽¹⁾ depending on the version.

[configure and order →](#)

WARNING!
link to the configurator to be integrated by the country

on-board technologies

To facilitate the driving experience, the controls are oriented towards the driver and the most important information is directly beneath their eyes.



Keep your eyes off the road: the new 210 cm² head-up display⁽¹⁾ projects essential information on to the windscreen.



find your speed, driver-assistance systems and navigation on the head-up display

Engine response and sound, steering firmness, ambient lighting and driver screen configuration driver's side. With multi-sense, customise your vehicle with up to 5 driving modes available⁽¹⁾ for a unique driving experience.



sport mode: intense driving pleasure



eco mode: optimised fuel consumption.

⁽¹⁾ depending on version or engine.

high-fidelity sound Harman Kardon⁽¹⁾

Enjoy an immersive sound experience with the new and exclusive Harman Kardon⁽¹⁾ system that delivers 485 watts of power through 12 speakers positioned around the passenger compartment.

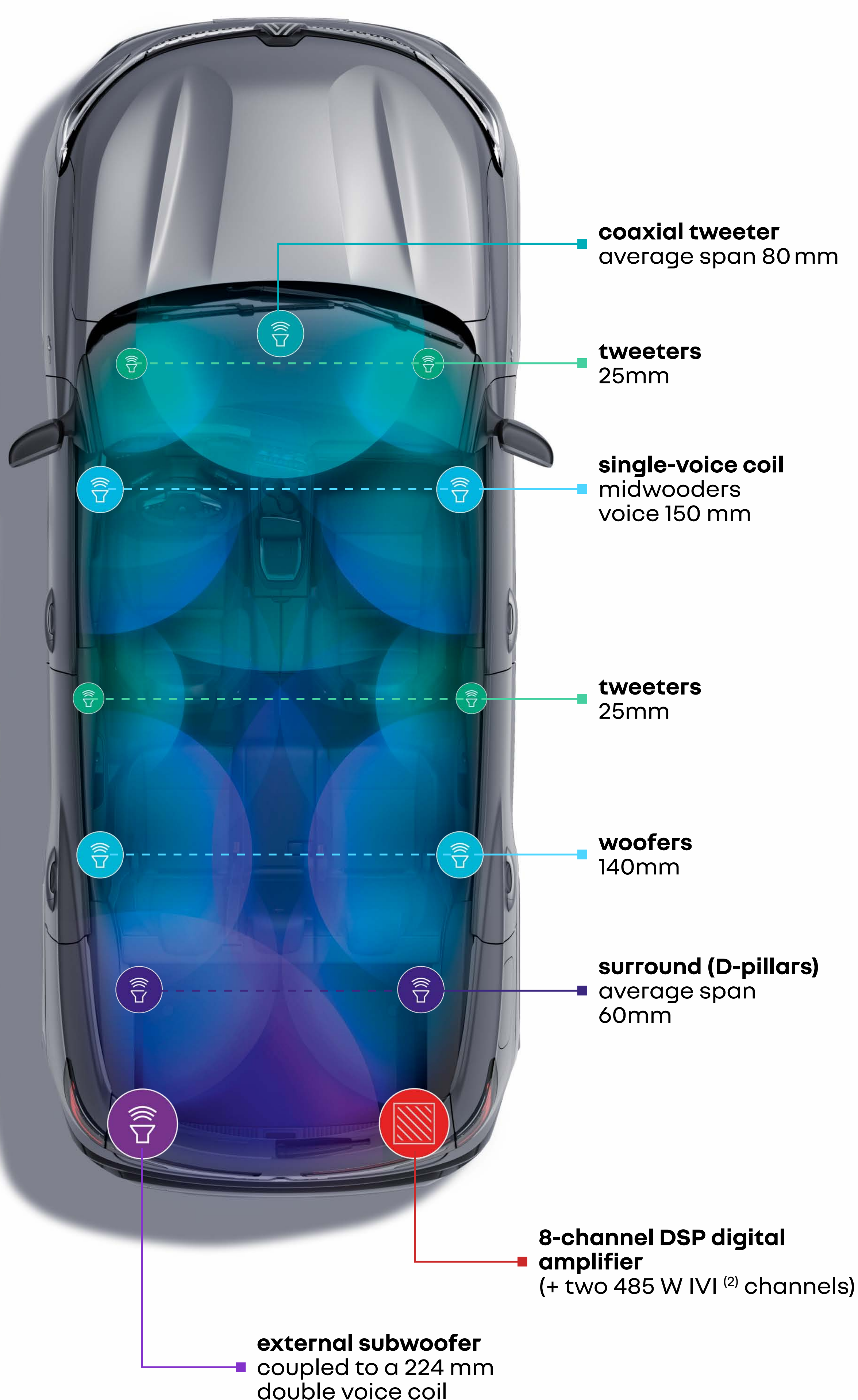

(1) depending on version.
(2) on-board Infotainment (IVI).

configure and order →

WARNING!
link to the configurator to be integrated by the country

openR link multimedia system with Google built-in

The openR link multimedia system and its 774 cm²(1) of intuitive technology incorporate the best My Renault connected services and with Google⁽¹⁾⁽²⁾ built-in.



Amazon Music, EasyPark, Radioplayer... more than 50 applications with exclusive content are available via Google Play⁽³⁾.



Waze is a community-based navigation app that shares information in real time. Waze boosts your peace of mind.



Drive to the beat with our new musical game – **SongPop for Renault!** Play together and rediscover popular songs with your family and friends!



Take to the road while listening to playlists, and much more, with **Amazon Music**, included with your Amazon Prime subscription.



Find all the sports news live in your car thanks to the **L'Equipe for Renault** app.



Vivaldi browser is an efficient, fast web browser that respects your privacy.



Access all your favourite radio stations live, at any time, in France or abroad, with **Radioplayer**.



Kabriol is the first audio-geolocated tourist guide for children. Hundreds of stories and geolocated information to keep you busy in the car.



Discover the stories around you thanks to **Karacal's** geolocated sound bubbles. Make every journey a new adventure.



Ready to play? Quizzes, riddles and challenges await you! With Renault and **Les Incollables**[®], travelling is fun for all the family.



With **EasyPark**, plan and book millions of parking spaces across Europe. Enter your destination's address or navigate using the map.



Sybel is a unique platform to find your favourite podcasts, and discover exclusive original creations, audio books, new documentaries, etc.

"Hey Google..." Talk to it to plan a journey, change driving mode or adjust the temperature. The voice assistant⁽²⁾ is always available.



Blocked road, new one-way street, temporary deviation... The Google Maps navigation system⁽²⁾ ensures precise driving even in the event of network loss.



(1) depending on version and country.

(2) My Renault, Google Maps and Google Assistant connected services are provided free of charge for 5 years from the date of delivery of your vehicle.

(3) using applications downloaded from Google Play requires a dedicated data package. To use these apps, share your phone's connection with your Renault. You can also subscribe to a pay-as-you-go offer from our partner Orange (offer without commitment) where the first 3 GB are free (valid for 6 months).

Google, Google Maps, Google News, Waze and other brand names are all trademarks of Google LLC.

configure and order →

WARNING!
link to the configurator to be integrated by the country

comfort and modular design

With the most knee room in its category⁽¹⁾, rear comfort is generous. The bench seat slides over 16 cm⁽²⁾, providing a larger boot.



Get up to 1,761 L of boot volume by folding down the rear seats⁽³⁾.



place your foot underneath the boot sill and it opens automatically thanks to the hands-free motorised tailgate

An ergonomic sliding hand rest enables you to to comfortably handle the large 12" openR screen.



hand rest and wireless smartphone charger

(1) source: A2MAC1 and Renault/2022.
(2) depending on version.
(3) depending on the engine, 1525 dm³ boot (VDA standard).

[configure and order →](#)

WARNING!
link to the configurator to be integrated by the country

06. advanced driver-assistance systems



32 advanced driving assistance systems

WARNING!
TEXT DELETED

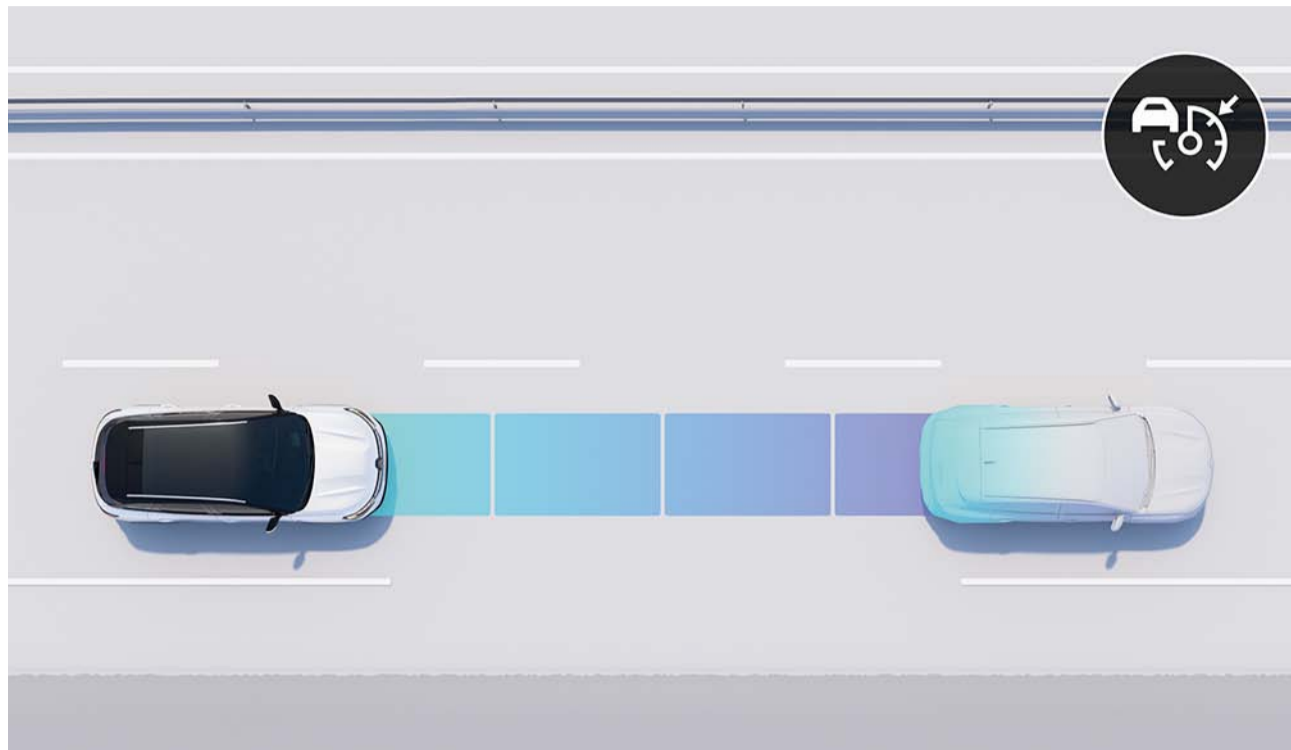

intelligent adaptive cruise control⁽¹⁾
It maintains a safe distance between you and the vehicle in front by activating the brakes when the distance is too short and the accelerator when the road is clear again. It analyses the surrounding environment to control your speed predictively.

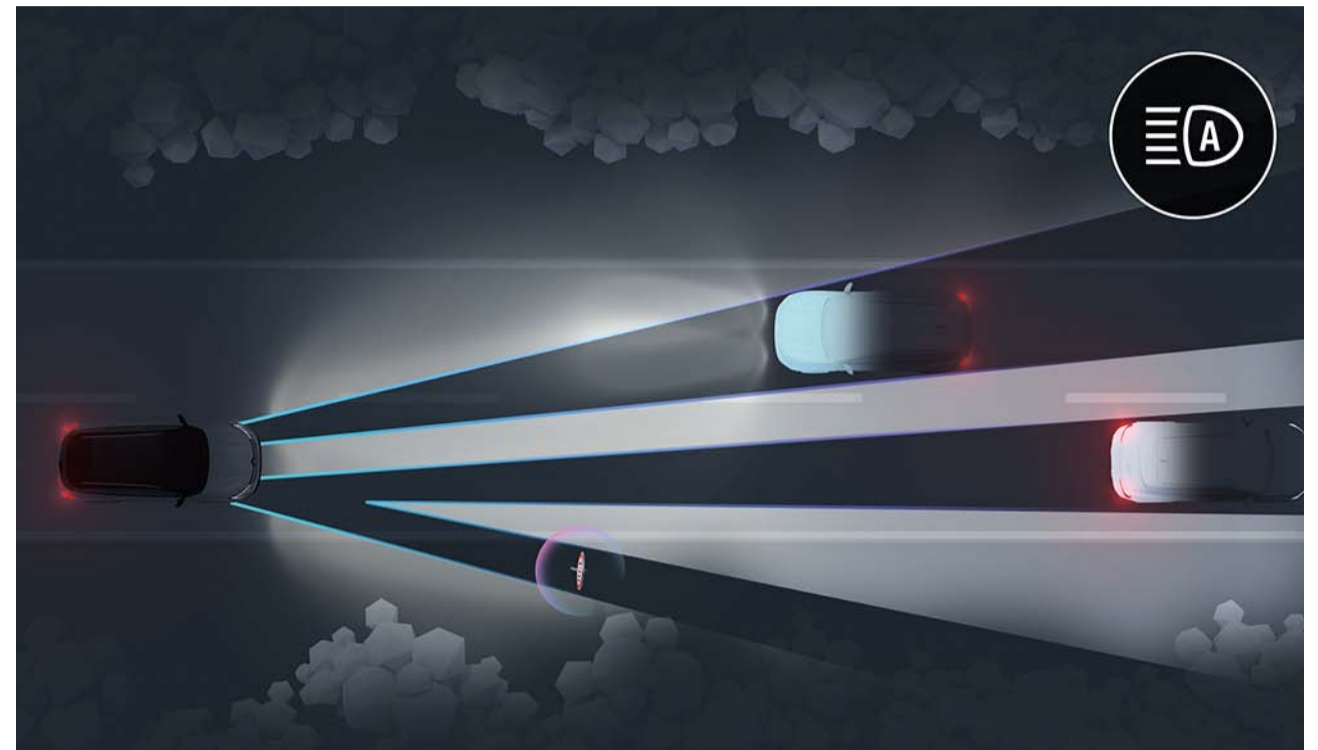

LED matrix vision headlights
The system automatically adjusts the light beam shape to the traffic and weather conditions to avoid glare and optimise night vision.



emergency braking when reversing
This system detects obstacles at the rear and stops the vehicle automatically in the event of danger.

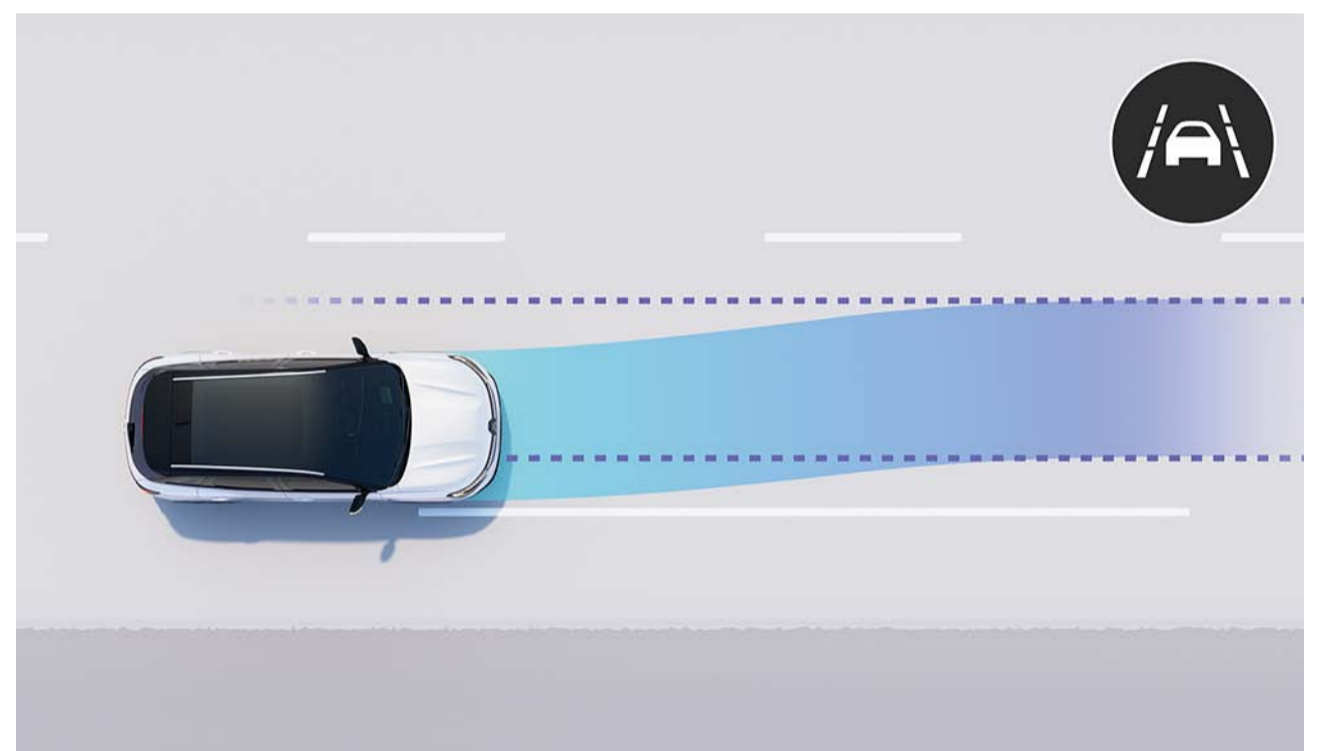

lane keeping assist
This system corrects the angle of the steering wheel, returning the vehicle to its lane unless you have indicated.



360° around view 3D camera
4 cameras, whose images recreate the vehicle's direct environment 360° around it, allow you to perform your manoeuvres effortlessly.



occupant safe exit alert
This system alerts you if a vehicle is approaching from the rear when you want to open the door.

driving

- active driver assist
- hill start assist
- 9.3" head-up display (210 cm²)
- safe following distance warning
- predictive eco-driver assistant⁽¹⁾⁽²⁾
- predictive hybrid driving⁽¹⁾⁽²⁾
- speed limiter
- cruise control
- adaptive cruise control
- adaptive cruise control smart⁽¹⁾

parking

- rear parking sensors
- front parking sensors
- side parking sensors
- 360° around view 3D camera
- reversing camera
- hands-free parking⁽³⁾

safety

- lane change warning
- lane departure warning
- occupant safe exit alert
- lane keeping assist
- blind spot warning
- automatic emergency braking with intersection function
- automatic emergency braking when reversing
- automatic emergency braking urban / suburban and with pedestrian / cyclist detection
- parking space exit warning when reversing
- lane departure prevention when overtaking.
- road sign recognition
- road sign recognition with speeding alert⁽¹⁾
- occupant safe exit alert
- driver attention alert system

lighting

- LED matrix vision headlights
- automatic main beam headlight activation
- LED adaptive vision headlights (with integrated fog light function)

(1) included for 5 years.

(2) coming soon.

(3) coming soon on E-Tech full hybrid engine.

configure and order →

WARNING!
link to the configurator to be integrated by the country

07. customisation

colours



glacier white⁽¹⁾ (co)



flame red⁽²⁾ (mp)



glossy pearl white⁽²⁾ (p)



starry black (mp)



iron blue (mp)



schist grey (mp)



satin schist grey (s)⁽³⁾

p: pearlescent.

s: satin.

co = clearcoat opaque.

mp: metallic paint.

(1) not available with starry black roof, in the Alpine esprit and iconic versions.

(2) not available on the evolution version.

(3) available only on the esprit Alpine version. photos not contractually binding.

configure and order →

WARNING!
link to the configurator to be integrated by the country

07. customisation

upholstery



**fabric upholstery
dark grey⁽¹⁾**



**mixed/distressed grey
fabric/textured coated
fabric upholstery⁽²⁾**



**mixed/black fabric
with gold-coloured
top-stitching/textured
coated fabric upholstery⁽³⁾**



**mixed carbon fabric/
Alcantara® upholstery
with blue top-stitching⁽⁴⁾**

- (1) available as standard on evolution version.
(2) available as standard on techno version.
(3) available as standard on iconic version.
(4) available as standard on esprit Alpine version.

wheels



17" maha alloy wheels⁽¹⁾



**18" altao black diamond-
cut alloy wheels⁽²⁾**



**19" komah black diamond-
cut alloy wheels⁽³⁾**



**20" effie black diamond-
cut alloy wheels⁽⁴⁾**



**20" daytona black
diamond-cut alloy wheels,
smoky grey clearcoat⁽⁵⁾**

- (1) available as standard on evolution version.
(2) available with extended grip pack on techno and iconic versions.
(3) available as standard on techno version.
(4) available as standard on iconic version.
(5) available as standard on esprit Alpine version.

configure and order →

WARNING!
link to the
configurator to
be integrated
by the country

accessories



customisation packs

Customise your vehicle's exterior trim with four colour packs: carbon effect, gold accents, light grey or satin metal grey.



Renault nouvelR roof box

Are you going with family or friends? Additional luggage can be stored in a new, secure and lockable Renault nouvelR roof box with a capacity of 380 litres, 480 litres or 630 litres.



electric retractable towbar

The 100% electric retractable towbar is automatically deployed by simply pressing a button located in the boot. It can be retracted in just a few seconds – it becomes invisible and protects the design of your vehicle.



sidesteps

Emphasise the robust style of Renault Austral with the sidesteps which make it easier to access accessories on the roof and protect the bodywork from everyday shocks.



esprit Alpine textile floor mats

Choose from a full range of mats to protect your vehicle's passenger compartment. Reaffirm its decidedly sporty look with an exclusive signature thanks to esprit Alpine textile floor mats.



download the accessories brochure PDF (6 MB)



configure and order →



07. customisation

engines

E-Tech full hybrid 200 hp	mild hybrid advanced 130 hp	mild hybrid 160 hp auto
energy		
full hybrid + unleaded petrol (E10)	unleaded petrol (E10)	
max. power kW EEC (hp) / engine speed of (rpm)		
96 kW at 4,500 rpm (internal combustion engine only)	96 kW at 4,500 rpm	116 kW/5 250 91 at 5,500 rpm
max. torque (Nm EEC) / engine speed of (rpm)		
205 N.m/1,750 rpm	230 N.m/1,750 at 3,500 rpm	270 N.m/1,800 at 3,750 rpm
batteries		
lithium-ion		
performance		
maximum speed (km/h)		
180		
0 - 100 km/h (s)		
8.4	10.8	9.7



**download the
engine PDF (6 MB)**



dimensions and volumes

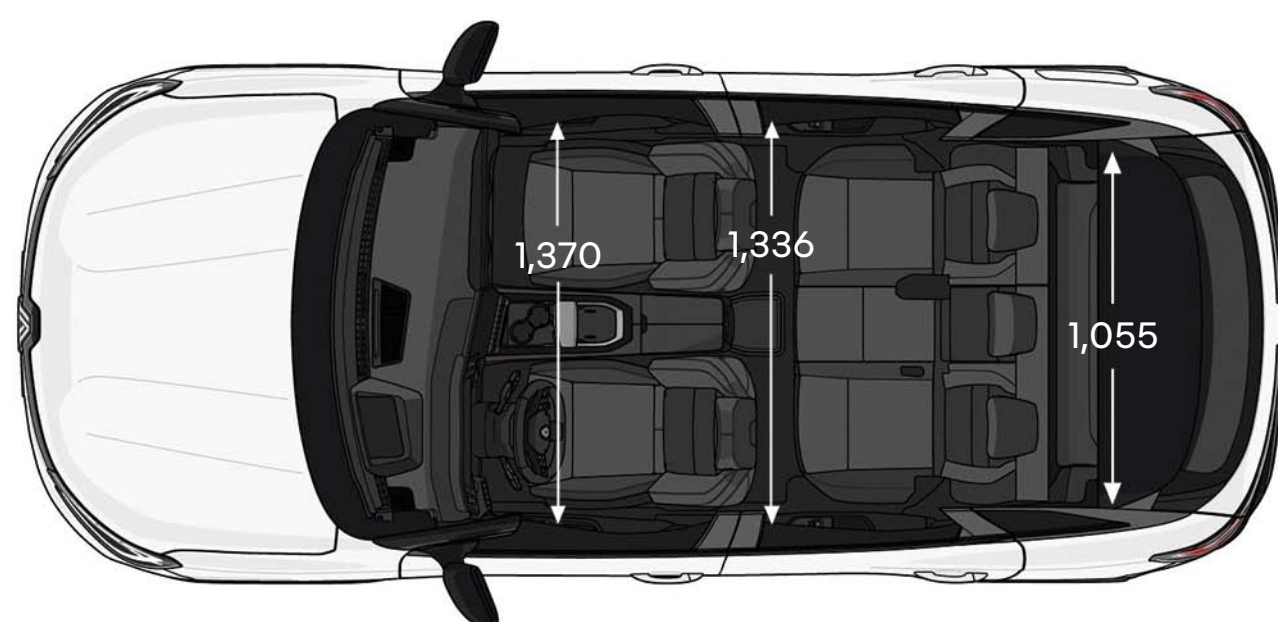
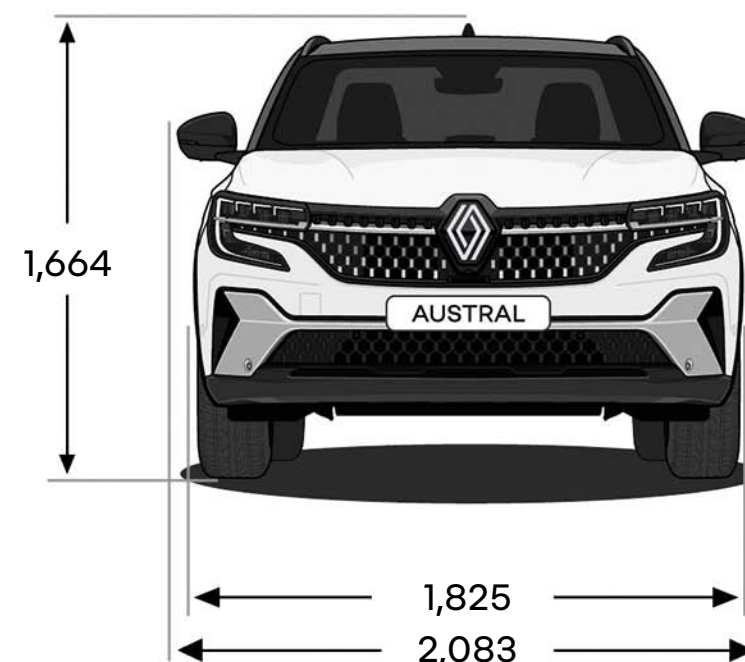
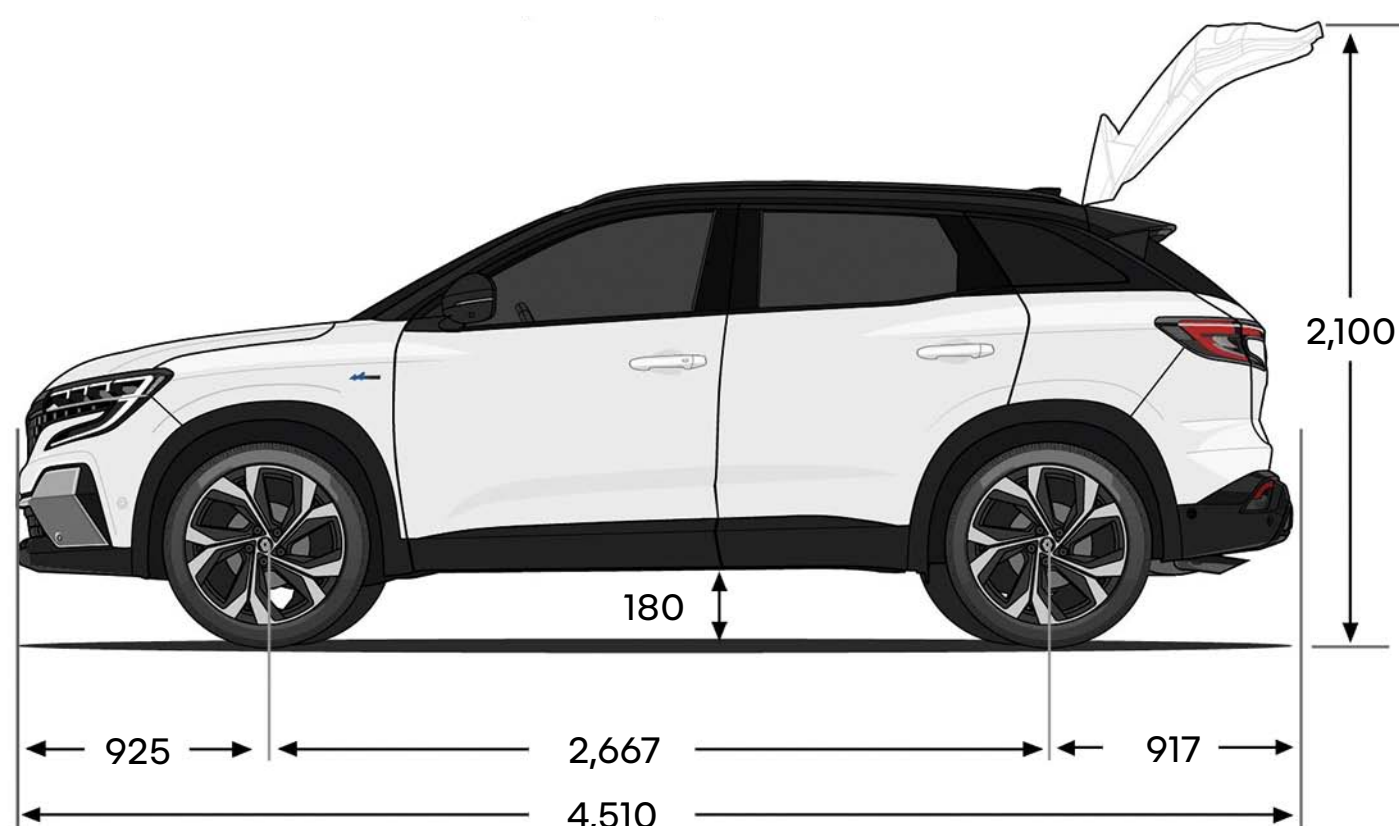

dimensions in (mm).

Boot volume (in litres)	mild hybrid mild hybrid advanced	E-Tech full hybrid
with fixed rear bench seat	555	527
with rear bench seat that can slide back 16 cm	up to 673	up to 657
max. with rear bench seat folded down	1,761	1,736

configure and order →

WARNING!
link to the configurator to be integrated by the country

the human first program is a comprehensive safety programme developed by Renault in cooperation with researchers, experts and firefighters.

because road safety concerns all road users, whether they are pedestrians, cyclists, motorists, the human first program by Renault undertakes to:

1. prevent accidents by developing safety equipment and advanced driving and safety assistance systems

up to **32** advanced driver assistance systems / more than 60 safety features, up to 7 airbags, child seats (Isofix), Renault Fixe4sure solution / more than 2,000 security-related patents filed since 1970

2. dealing with accidents based on innovations developed with the fire service

QRescue / Fireman Access / more than 5,000 firefighters trained over 10 years in **20** countries worldwide / around 400 cars donated per year for their training

3. reduce the number of accidents and their severity by investing massively in R&D

safety score / safety coach / connected services / big data / artificial intelligence and cybersecurity systems



find out more about the human first program

Renault care service

Replace what is necessary, at the right time. Thanks to its connected and predictive maintenance features, it is easy to service your Renault Austral E-Tech full hybrid. And thanks to the My Renault application, quotes, online appointments and even service history are at your fingertips.

[find out more about Renault care service](#)





Every precaution has been taken to ensure that the contents of this brochure were accurate and up-to-date at the time of publication. This document has been created using pre-production and prototype models. In line with its policy of continuous product improvement, Renault reserves the right to modify the specifications, vehicles and accessories described and featured at any time. Any such modifications are communicated to Renault dealers as quickly as possible. Depending on the country of sale, versions may differ and some equipment may be unavailable (standard, optional or accessory). Please contact your nearest dealer for the latest information. For reasons to do with the medium, the colours featured in this document may differ slightly from those of the actual paintwork or interior trim. All rights reserved. Reproduction in any format and by any means of all or part of this brochure is prohibited without prior written authorisation from Renault.

Publicis - photo credits: P. McLean, © Renault Marketing 3D-Commerce - xxxxxxxxxxxx - may 2024.
 Renault s.a.s, a French simplified joint stock company with a share capital of €533,941,113.00 / 122-122 bis avenue du Général Leclerc - 92100 Boulogne-Billancourt Cedex, France - registered on the Trade and Companies Registry (R.C.S.) of Nanterre under number B 780 129 987 / tel.: 0806 00 20 20.

Renault recommends 



WARNING!
 link to social networks to be integrated by countries

configure and order →

WARNING!
 link to the configurator to be integrated by the country

RENAULT AUSTRAL E-TECH FULL HYBRID

200 HP



also available for mild hybrid advanced and mild hybrid

- 01. interior trims**
- 02. equipment**
- 03. engines**
- 04. equipment and options**

01. interior trims



evolution



techno



techno esprit Alpine



iconic



iconic esprit Alpine

02. equipment

evolution

design

- starry black shark aerial
- ice black chequered grille
- 17" maha alloy wheel rims
- pure vision LED headlights

on-board experience

- fixed rear bench seat
- hands-free card
- automatic dual zone heating and air conditioning system
- automatic windscreen wipers
- electric parking brake with auto-hold function
- electrically folding door mirrors
- 12.3" openR instrument panel

- 9" openR link: connected multimedia system with Google built-in including navigation pack (Google Maps and Google Assistant) for 5 years and infotainment pack (Google Play⁽¹⁾)
- smartphone mirroring (wireless) Android Auto™ and Apple CarPlay™
- digital operating instructions in the vehicle's multimedia system
- manually adjustable driver and passenger seats
- Arkamys® auditorium audio system with 6 speakers

advanced driver-assistance systems

- adaptive cruise control
- traffic sign recognition with speed alert
- front and side parking distance control
- reversing camera
- lane departure warning
- lane keeping assist
- intercity/suburban automatic emergency braking with pedestrian/cyclist detection
- automatic emergency brake assist with intersection function
- road sign recognition

connected services

- emergency call
- auto-update included for 5 years
- remote services pack (via the My Renault application) included for 5 years

packs

- temporary spare wheel (with false floor)
- safety pack
- power driver seat pack

options

- 18" all-weather tyres
- heated front seats

techno (evolution+)

design

- 19" komah black diamond-cut alloy wheels
- tinted rear windows

on-board experience

- rear bench seat that can slide back 16 cm
- wireless smartphone charger
- multi-sense

- openR link 12": connected multimedia system with Google built-in including navigation pack (Google Maps and Google Assistant) for 5 years and infotainment pack (Google Play⁽¹⁾)
- electrochromic rimless rearview mirror
- height-adjustable passenger seat
- grained coated fabric/textile upholstery
- steering wheel

advanced driver-assistance systems

- automatic main/dipped beam headlight activation
- adaptive vision LED headlights (with integrated fog light function)

packs

- city premium pack
- extended grip pack
- safety pack

- sunroof pack and roof bars chrome appearance
- premium winter pack

options

- power **tailgate**
- temporary spare wheel
- starry black roof

techno esprit Alpine (techno +)

design

- satin black roof bars
- front bumper incorporating a satin grey sports blade
- 20" daytona black diamond-cut alloy wheels with smoky grey clearcoat
- glossy black front and rear logos
- satin grey badge
- Alcantara® finish for the instrument panel and door panels

- aluminium pedal unit
- mixed carbon fabric/Alcantara® upholstery with blue top-stitching
- special grained coated textile steering wheel with Alcantara® insert

on-board experience

- fixed rear bench seat

packs

- city premium pack⁽²⁾
- safety pack
- winter comfort pack

options

- 4Control advanced (only on E-Tech full hybrid)
- rear bench seat that can slide back 16 cm
- power **tailgate**
- starry black roof
- panoramic glass sunroof
- temporary spare wheel

iconic (techno +)

design

- chrome-look roof bars
- front bumper incorporating a body-coloured sports blade
- 20" effie black diamond-cut alloy wheels

- hands-free powered tailgate
- heated windscreen
- electric driver's seat with lumbar massage
- heated driver and passenger seats

advanced driver-assistance systems

- rear parking space exit warning
- blind spot warning
- rear detection with emergency trajectory correction
- 360° around view 3D camera

- hands-free parking
- automatic emergency braking when reversing

packs

- **premium driving** pack (with connected driving pack included for 5 years) and 9.3" head-up display
- Harman Kardon® pack

options

- 4Control advanced (only on E-Tech full hybrid)
- LED matrix vision headlights
- panoramic glass sunroof
- starry black roof
- temporary spare wheel

iconic esprit Alpine (iconic +)

design

- satin black roof bars
- front bumper incorporating a satin grey sports blade
- Alcantara® finish for the instrument panel and door panels
- 20" daytona black diamond-cut alloy wheels with smoky grey clearcoat
- glossy black logo
- satin grey badge
- aluminium pedal unit

- mixed carbon fabric/Alcantara® upholstery with blue top-stitching
- special grained coated textile steering wheel with Alcantara® insert

on-board experience

- electric passenger seat

advanced driver-assistance systems

- predictive eco-driving assistant (only with mild hybrid auto)
- predictive hybrid driving (only with E-Tech full hybrid)
- active driver assist

pack

- Harman Kardon® pack

options

- 4Control advanced (only on E-Tech full hybrid)
- 9.3" head-up display
- LED matrix vision headlights
- panoramic glass sunroof
- temporary spare wheel

(1) using applications downloaded from Google Play requires a dedicated data package. To use these apps, share your phone's connection with your Renault. You can also subscribe to a pay-as-you-go offer from our partner Orange (offer without commitment) where the first 3 GB are free (valid for 6 months). Android Auto™ is a trademark of Google Inc. Apple CarPlay™ is a trademark of Apple Inc. Google, Google Maps, Google News, Waze and other marks are trademarks of Google LLC.

03. engines

	E-Tech full hybrid 200	mild hybrid advanced 130	mild hybrid 160 auto
energy	unleaded fuel (E10) + full hybrid	unleaded petrol (E10)	unleaded petrol (E10)
fiscal rating (hp) (France)	7	7	8
engine			
internal combustion engine	3 cylinders, 1.2 L turbocharged, 96 kW / 205 Nm	3-cylinder, 1.2 L turbocharged; GDI	4-cylinder, 1.3 L turbocharged; GDI
capacity (cm ³)	1,199	1,199	1,333
electric motor (kW/Nm)	50/205	12 in engine mode	N/A
max power (kW EEC) at (rpm)	146 (200 hp)	96 (130 hp) 4,500 - 5,500	116 (160 hp) 5,250 - 5,500
max. torque EEC (Nm) at (rpm)	205 + 205 (non-cumulative)	230 1,750 - 3,500	270 1,800 - 3,750
gearbox	multimode automatic 15 combinations	6-speed manual gearbox	automatic
battery			
battery type		lithium-ion	
voltage (V)	400	48	12
capacity (kWh)	2	0.925	0.15
chassis and steering			
tyre dimensions	215/65 R17 235/55 R18 205/55 R19 235 / 45 R20	215/65 R17 235/55 R18 205/55 R19 235 / 45 R20	215/65 R17 235/55 R18 205/55 R19 235 / 45 R20
power steering		Yes (electric)	
turning circle (m)	11.4 (10.1 with 4Control advanced)	11.2	11.2
performance			
maximum speed (km/h)		180	
0 - 100 km/h (s)	8.4	10.8	9.7
1,000m stopping distance (s)	30.8	32.2	31.05
mid-range acceleration: 80 km/h to 120 km/h (s)	5.6	NA	N/A
certification			
protocol		WLTP ⁽¹⁾	
emission control standard		Euro 6 D-Full	
WLTP fuel consumptions and emissions⁽²⁾ (from)			
CO ₂ (g/km)	102	118	139
consumption over a combined cycle (L/100 km)	4.6	5.2	6.2
volumes and weights			
fuel tank (l)		55 without reserve (3 litres of reserve)	
kerb weight (kg)	1,517/1,627	1421	1,464
gross vehicle weight (GVW) (kg)	2,101/2,153	1,994	2,003
gross train weight (GTW) (kg)	3,601/3,653	3,494	3,803
max. braked towing weight (kg)	1,500	1,500	1,800

(1) WLTP (Worldwide Harmonized Light Vehicle Test Procedures): this new protocol provides results much closer to those found in daily use compared to the NEDC protocol.

(2) fuel consumption and CO₂ emissions are certified using a standard, regulatory method. This method is identical for all manufacturers and enables vehicles to be compared.

04. equipment and options

	evolution	techno	techno esprit Alpine	iconic	iconic esprit Alpine
advanced driver-assistance systems					
active driver assist: intelligent adaptive cruise control ⁽¹⁾ + lane keeping assist	-	-	-	premium driving pack	■
hill start assist	■	■	■	■	■
safe following distance warning	■	■	■	■	■
predictive eco-driving assistant (only on mild hybrid auto)	-	-	-	premium driving pack	■
predictive hybrid driving (only with E-Tech full hybrid)	-	-	-	premium driving pack	■
speed limiter and cruise control	■	■	■	■	■
adaptive cruise control	■	■	■	■	■
parking					
front parking sensors	■	■	■	■	■
rear parking sensors	■	■	■	■	■
side parking sensors	■	■	■	■	■
360° around view 3D camera	-	city pack premium	city pack premium	■	■
reversing camera	■	■	■	■	■
hands-free parking	-	city pack premium	city pack premium	■	■
safety					
lane change warning + lane keeping assist	■	■	■	■	■
lane departure warning	■	■	■	■	■
lane keeping assist	■	■	■	■	■
blind spot warning	safety pack	safety pack	safety pack	■	■
rear detection with emergency trajectory correction	safety pack	safety pack	safety pack	■	■
rear parking space exit warning	■	■	■	■	■
automatic emergency braking system junction function	■	■	■	■	■
automatic emergency braking when reversing	safety pack	safety pack	safety pack	■	■
urban/suburban automatic emergency braking and pedestrian/cyclist detection	■	■	■	■	■
traffic sign recognition	■	■	■	■	■
traffic sign recognition with speeding alert	■	■	■	■	■
occupant safe exit alert	safety pack	safety pack	safety pack	■	■
driver attention alert	■	■	■	■	■
lighting					
pure vision LED headlights	■	-	-	-	-
automatic switching between main/dipped beam headlights	-	■	■	■	■
adaptive vision LED headlights (with integrated fog function)	-	■	■	■	■
on-board experience					
rear bench seat that can slide back 16 cm	-	■	o / winter comfort pack	■	■
fixed rear bench seat	■	-	■	-	-
Renault hands-free opening and start card	■	■	■	■	■
wireless smartphone charger	-	■	■	■	■
automatic dual zone heating and air conditioning system	■	■	■	■	■
automatic windscreen wipers	■	■	■	■	■
electric parking brake with auto-hold function	■	■	■	■	■
power tailgate	-	o	o	-	-
power tailgate handsfree	-	-	-	■	■
door sill welcome light with logo projection	-	city pack premium	city pack premium	■	■
multi-sense: customisation of driving modes and interior trim	-	■	■	■	■
digital operating instructions in the vehicle's multimedia system	■	■	■	■	■
9" openR link: connected multimedia system with Google built-in including navigation pack (Google Maps and Google Assistant) for 5 years and infotainment pack (Google Play ⁽²⁾)	■	-	-	-	-
12" openR link: connected multimedia system with Google built-in including navigation pack (Google Maps and Google Assistant) for 5 years and infotainment pack (Google Play ⁽²⁾)	-	■	■	■	■
heated windscreen	-	winter pack premium	winter pack comfort	■	■
smartphone mirroring (wireless) compatible with Android Auto™ and Apple CarPlay™	■	■	■	■	■
electrically folding door mirrors	■	■	■	■	■
electric driver's seat with lumbar massage	o	winter pack premium	winter pack comfort	■	■
heated driver and passenger seats	o	winter pack premium	winter pack comfort	■	■
manually adjustable driver and passenger seats	■	■	■	-	-
electric and heated passenger seat	-	-	winter pack comfort	-	■
electric and heated passenger seat	-	■	■	■	■
mixed carbon fabric/Alcantara® upholstery with blue top-stitching	-	-	■	-	■
mixed/distressed grey fabric/textured coated fabric upholstery	-	■	-	-	-
mixed/black fabric with gold-coloured top-stitching/textured coated fabric upholstery	-	-	-	■	-

04. equipment and options

	evolution	techno	techno esprit Alpine	iconic	iconic esprit Alpine
on-board experience (continued)					
dark grey fabric upholstery	■	-	-	-	-
Arkamys® auditorium audio system with 6 speakers	■	■	■	■	■
12.3" openR link instrument panel	■	■	■	■	■
heated steering wheel	-	winter pack premium	winter pack comfort	■	■
design					
shark fin aerial	■	■	■	■	■
chrome-look roof bars	-	o	-	■	-
satin black roof bars	-	-	■	-	■
front bumper with satin grey sports blade	-	-	■	-	■
front bumper with body-coloured sports blade	-	-	-	■	-
ice black chequered grille	■	■	■	■	■
Alcantara® finish for the instrument panel and door panels	-	-	■	-	■
17" maha alloy wheel rims	■	-	-	-	-
19" komah black diamond-cut alloy wheels	-	■	-	-	-
20" daytona smoky grey diamond-cut alloy wheels	-	-	■	-	■
20" effie black diamond-cut alloy wheels	-	-	-	■	-
ice black front and rear logo	-	-	■	-	■
satin grey badge	-	-	■	-	■
aluminium pedal unit	-	-	■	-	■
rimless and electrochromatic interior rear-view mirror	-	■	■	■	■
tinted rear windows	-	■	■	■	■
special grained coated textile steering wheel with Alcantara® insert	-	-	■	-	■
connected services					
emergency call	■	■	■	■	■
auto-update included for 5 years	■	■	■	■	■
navigation pack with 12" openR link: connected multimedia system with Google built-in and navigation pack (Google Maps and Google Assistant) for 5 years, and infotainment pack (Google Play ⁽²⁾)	-	■	■	■	■
remote services pack (via the My Renault application) included for 5 years	■	■	■	■	■
packs					
city premium pack: 360° around view 3D camera, wing mirrors with memory function, hands-free parking and door sill welcome light with logo projection	-	o	o	-	-
premium winter pack: electric driver's seat with lumbar massage, heated front seats, windscreen and steering wheel	-	o	-	-	-
winter comfort pack: electric front seats with lumbar massage on driver's side, sliding rear bench seat, heated front seats and steering wheel	-	-	o	-	-
temporary spare wheel pack (and false floor)	o	-	-	-	-
extended grip pack: extended grip and all-weather tyres (including 18" altao black diamond-cut alloy wheels)	-	o	-	-	-
safety pack: blind spot warning and lane departure prevention when overtaking, automatic emergency braking when reversing and occupant safety exit	o	o	o	-	-
premium driving pack: 9.3" head-up display; active driver assist, road sign recognition and speeding alert, predictive hybrid driving	-	-	-	o	-
power driver seat pack and electric driver's seat with lumbar massage	o	-	-	-	-
sunroof pack: panoramic glass sunroof and chrome-finish roof bars	-	o	-	-	-
4-season pack: all-weather tyres (includes 18" altao black diamond-cut alloy wheels)	o	o	-	-	-
Harman Kardon® pack	-	-	-	o	o
options					
4Control advanced (only on E-Tech full hybrid)	-	-	o	o	o
9.3" head-up display	-	-	-	premium driving pack	o
rear bench seat that can slide back 16 cm	-	-	o/winter comfort pack	-	-
LED matrix vision headlights	-	-	-	o	o
20" all-weather tyres	-	-	o	o	o
heated front seats	o	winter pack premium	winter pack comfort	■	■
spare wheel	temporary spare wheel	o	o	o	o
starry black roof	-	o	o	o	o
panoramic glass sunroof	-	sunroof pack	o	o	o

■: standard. o: option. -: not available. (1) included for 5 years. (2) using applications downloaded from Google Play requires a dedicated data package. To use these apps, share your phone's connection with your Renault. You can also subscribe to a pay-as-you-go offer from our partner Orange (offer without commitment) where the first 3 GB are free (valid for 6 months). (3) contact your sales advisor for more details on the leather materials used. All seats mentioned as being leather in this document are composed partly of real leather and partly of textured coated fabric. Google, Google Maps, Google News, Waze and other brand names are all trademarks of Google LLC.

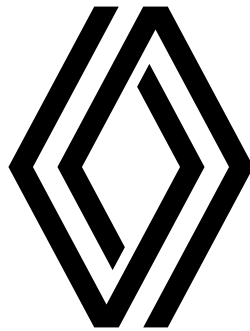

Every precaution was taken to ensure that these technical specifications were accurate and up-to-date when disclosed. This document has been created using pre-production and prototype models. In line with its policy of continuous product improvement, Renault reserves the right to modify the specifications, vehicles and accessories described and featured at any time. Any such modifications are communicated to Renault dealers as quickly as possible. Depending on the country of sale, certain versions may differ and certain equipment may be unavailable (as standard, as an option or as an accessory). Please contact your nearest dealer for the latest information. Because of the limitations associated with the medium, the colours featured in this document may differ slightly from those of the actual paintwork or interior trim. All rights reserved. Reproduction in any format and by any means of all or part of these specifications is prohibited without prior written authorisation from Renault.